



PANEL KIT INSTALLATION MANUAL

OWN | EARN | EXPAND



BUILT TO **LAST**. DESIGNED TO **EARN**.



WHAT'S INCLUDED:

(36) 4' PANELS + 62 PANEL CONNECTORS



62

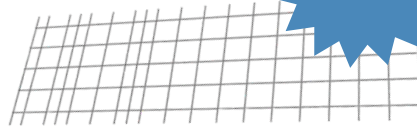
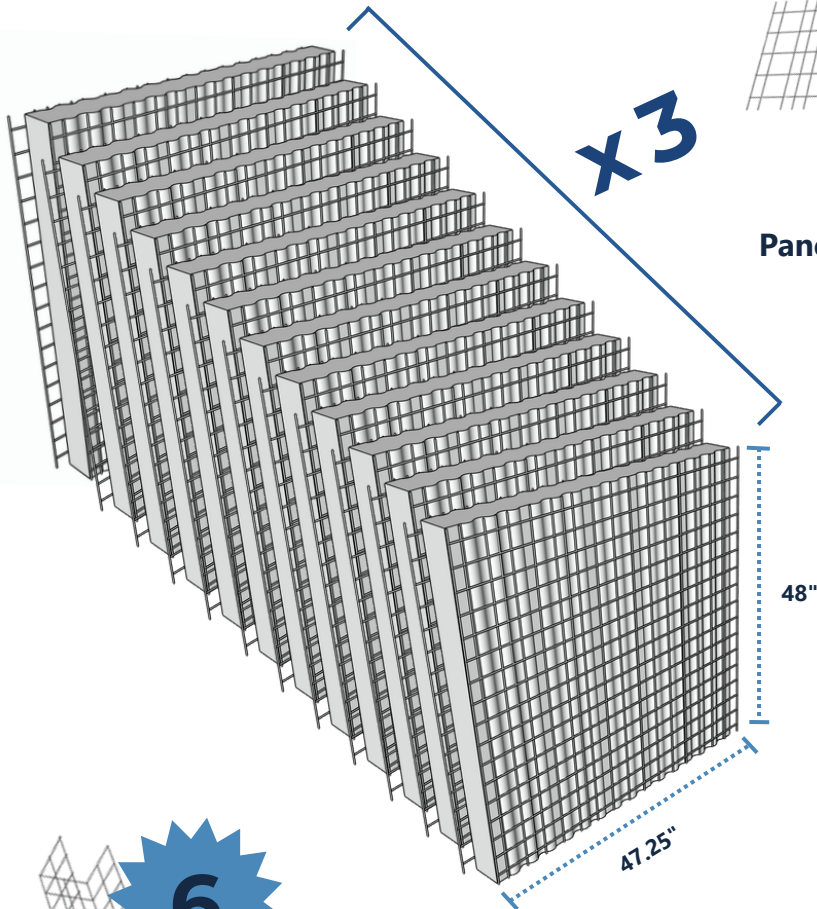

Panel Connectors

4' x 20"

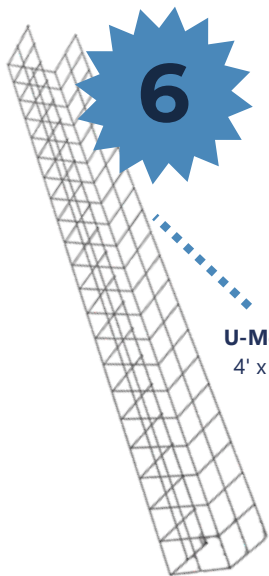

U-Mesh
4' x 4"

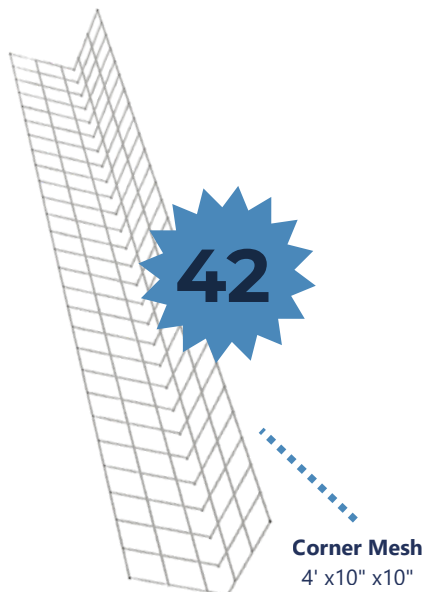

Corner Mesh
4' x10" x10"

-  ENGINEERED DRAWINGS AND BUILD SPECIFICATIONS
-  ELIGIBILITY FOR FORTIUNIT CERTIFICATION AND BRANDING
-  MARKETING STARTER KIT



WHAT'S NOT INCLUDED:

- CONCRETE SLAB OR FOUNDATION
- DOOR HARDWARE AND LOCKS
- LAND, PERMITS, OR SITE PREPARATION

FORTIUNIT PRODUCT SPECIFICATIONS

Manufactured by  FORTIFIED
STRUCTURAL SOLUTIONS
USA

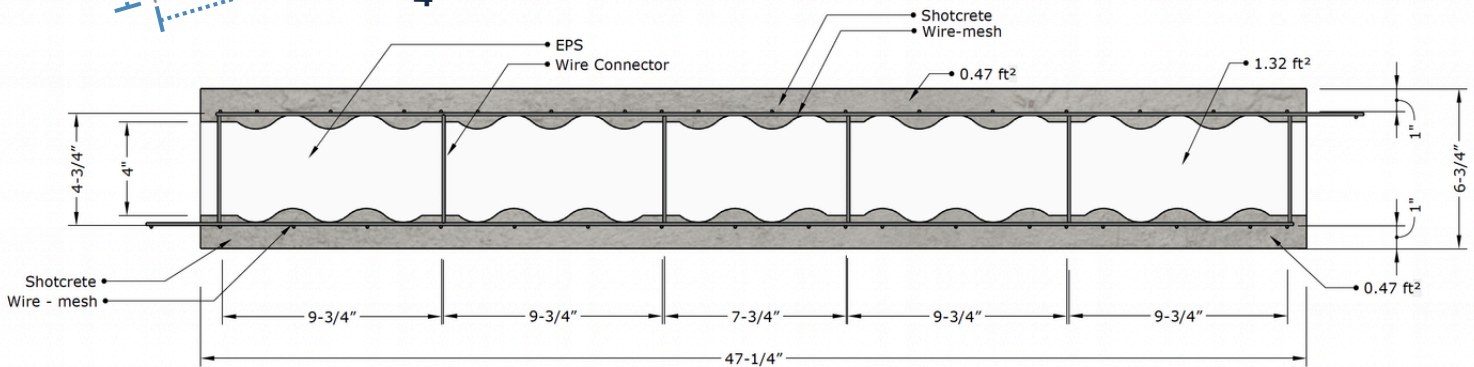
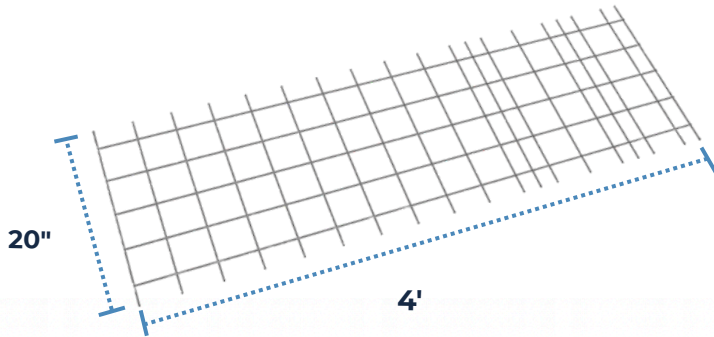
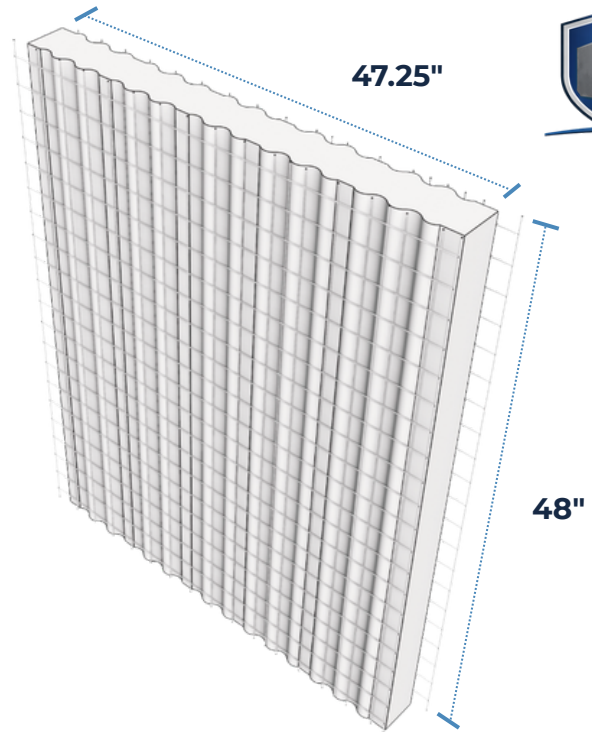

MATERIALS CHARACTERISTICS

Expanded Polystyrene (EPS) Foam

Type I modified EPS Board - ASTM C578
Density 1 pound per cubic foot
Flame-spread index ≤ 25
Smoke-developed index ≤ 450

Concrete/Mortar (applied in-situ)

Compressive Strength $> 2,500$ PSI
Thickness > 1 "
Aggregate size $< 5/8$ "
Slump > 2 "

Weight

Panel sheet (lb/ft²): 1.01
Finished wall (lb/ft²): 21.50

Wire Connector

11 gauge galvanized wire - ASTM A1064
Yield Strength: 115 ksi

Thermal coefficient (R Value)

(F.hr.ft²/Btu)(°F)

@ 25° | 17.4
@ 40° | 16.7
@ 70° | 15.4

Acoustic coefficient (Cw)

42 dB

Wire-mesh Reinforcement

L 3.15" x T 2.95" 11 gauge galvanized wire - ASTM A1064
Yield Strength: 115 ksi

TOOLS & MATERIALS

Find links to recommended products at store.fortiunit.com/tools



Measurement Tool
Chalk Line or Tape



Concrete Drill
Hammer Drill, 6.5-Amp



Epoxy Glue
Anchoring Adhesive



Heat Tool
Temperature Gun or Torch



Rebar Dowels - 37 Pieces
#3 - 3/8-inch x 2 feet



Pneumatic C Ring Gun
16 Gauge 1/2-Inch



C-Ring Staples
16 Gauge 1/2" Inner Crown 5/8"



Tie Wire
16.5-Gauge



Pliers
Slip Joint & Diagonal



Trowel
12 in. x 4 in.



Mallet
Rubber or Dead Blow



Mortar Materials
Portland, Sand, Water



Concrete Sprayer
with Air Compressor



Bonding Agent
Adhesive Additive



Cement Fibers
Anti-Cracking Additive



Mixing Container
3.5 Cu.Ft Usable Volume



Concrete Forms
Wood/Plastic/Metal
~2x4" Plank



Level
I-Beam Level



Screed Edge
> 4' Length



Heat Knife
> 4" Blade Length



Sponges
7.5 in. All Purpose



Drill Bit
7/16"



Shoring and bracing systems may be either rented or temporarily constructed using structural wood, plastic, or metal materials.

SCAN TO SHOP RECOMMENDED TOOLS & MATERIALS:



ASSEMBLE (12) WALL PANELS



Cut **three (3) 4-foot panel sections** into **four (4) pieces of 1-foot length**, then divide each piece as required to produce a total of **twelve (12) Part B sections**. Ensure cuts are clean and edges are prepared as needed for proper placement and connection.

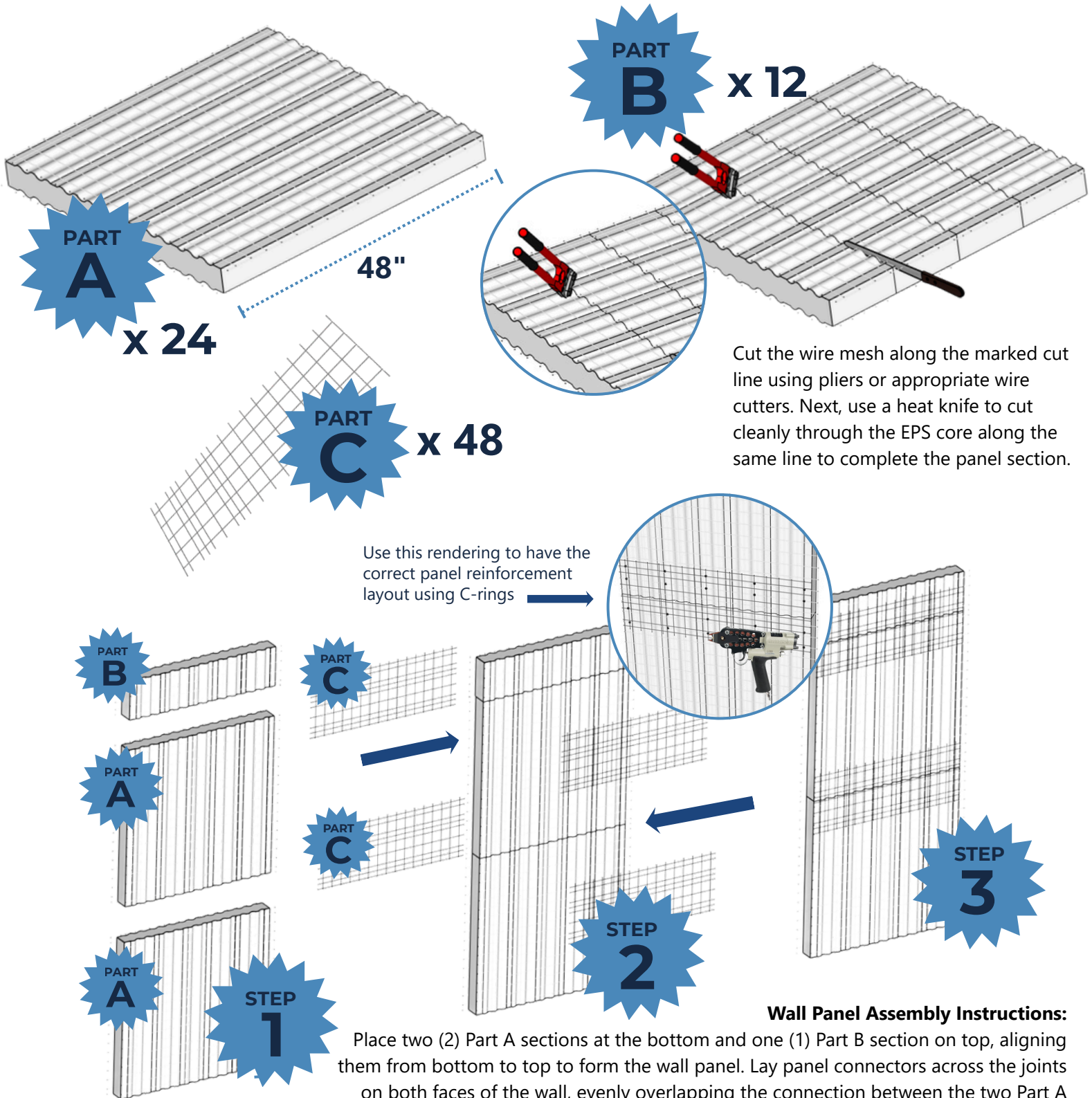

Cut the wire mesh along the marked cut line using pliers or appropriate wire cutters. Next, use a heat knife to cut cleanly through the EPS core along the same line to complete the panel section.

Wall Panel Assembly Instructions:

Place two (2) Part A sections at the bottom and one (1) Part B section on top, aligning them from bottom to top to form the wall panel. Lay panel connectors across the joints on both faces of the wall, evenly overlapping the connection between the two Part A sections and the Part B section. Secure the connectors to the panel wire mesh using ~20 C-rings at multiple points on both sides of the wall assembly to ensure the sections are firmly connected.

1

Reference Diagrams: Foundation Measurements & Dowel Layout

Use these diagrams to verify slab dimensions, wall layout alignment, and rebar dowel spacing prior to marking and panel placement.

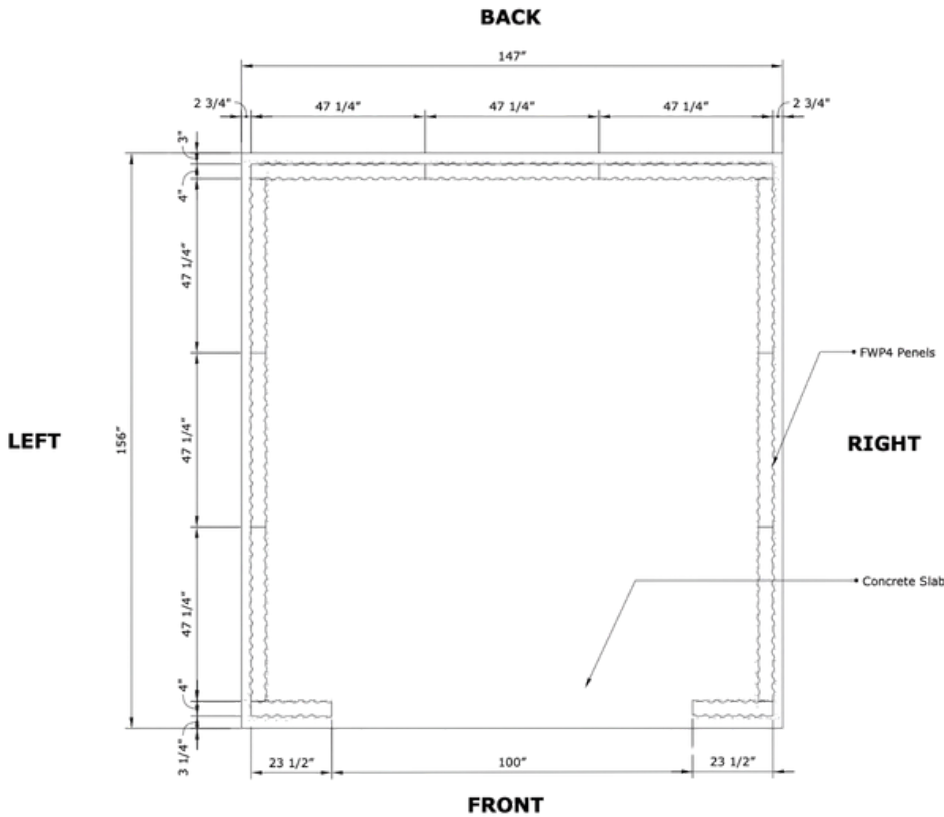

Foundation Measurement Diagram:

Confirm all slab or footer dimensions before layout begins. A minimum slab size of 14' x 14' is recommended to allow sufficient space for panel staging, bracing, and safe material handling. Verify square corners using diagonal measurements and ensure all wall lines, openings, and structural reference points match the approved plans.

FLOOR PLAN VIEW - DIMENSIONED



Rebar Dowel Placement Diagram:

Dowel locations must be based on the panel frame dimensions—not the finished structure size. The finished structure measures 147" W x 156" D, while the assembled SCIP panel frame (prior to concrete finishing) fits within 141 3/4" W x 149 3/4" D. This difference is critical, as the concrete finish accounts for the added thickness beyond the panel and rebar placement. Mark and drill dowel holes according to the panel frame layout, spacing approximately 14 inches on center and alternating sides to create a staggered anchoring pattern. Ensure alignment with panel cores for proper structural connection.

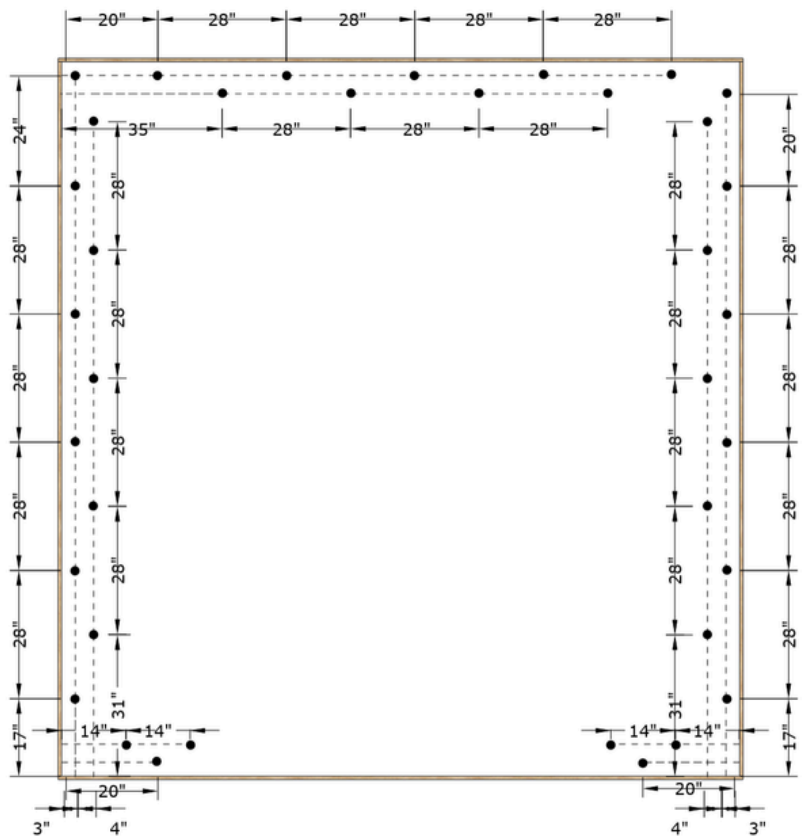

1b Foundation Preparation and Layout Marking

Snap chalk lines or stretch string to mark the perimeter of each wall on the slab or footer. Use measuring tape and squares to define corners and door/window locations. Mark dowel hole positions approximately every 14 inches, alternating sides along the panel for a staggered anchor pattern.

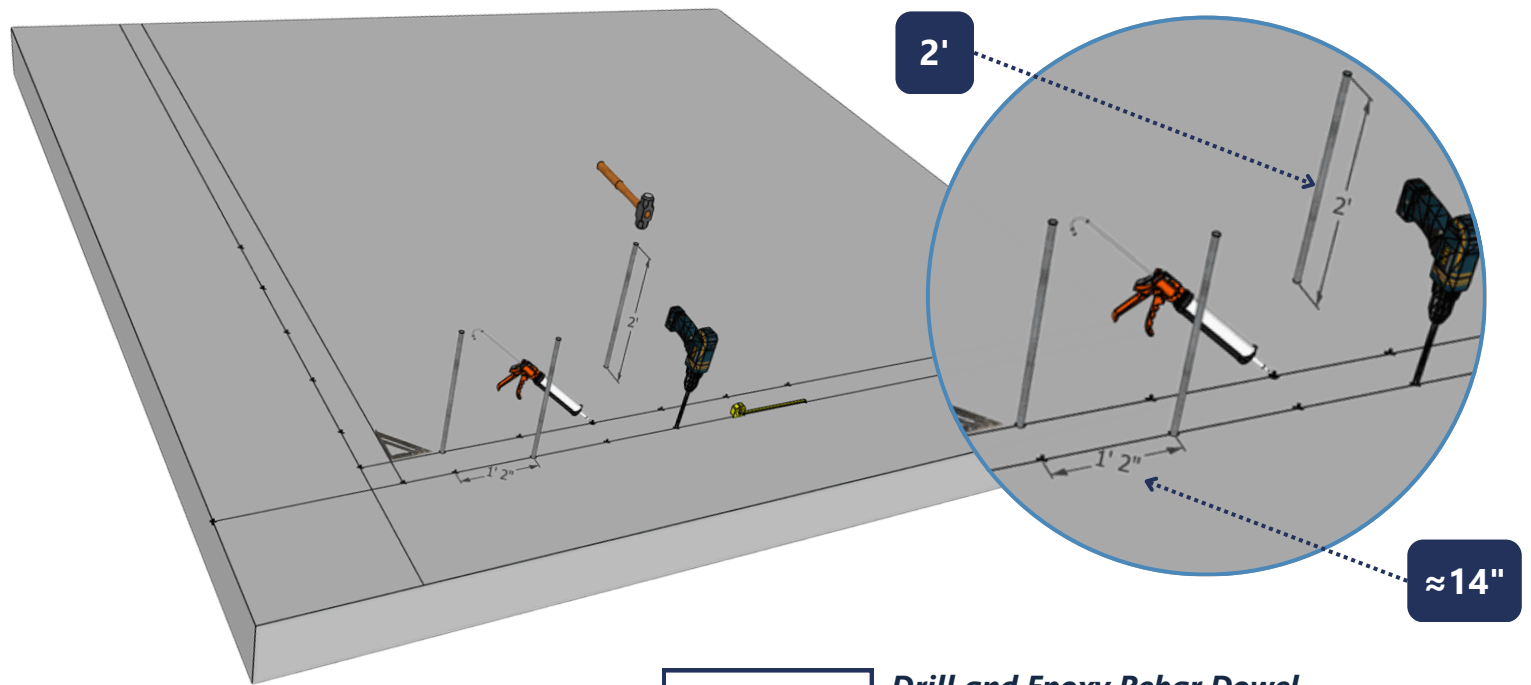

1c - 1e

Drill and Epoxy Rebar Dowel

Drill holes approximately 4 inches deep, fill each with epoxy, insert dowels by hammering them in, and allow to cure fully before panel placement.

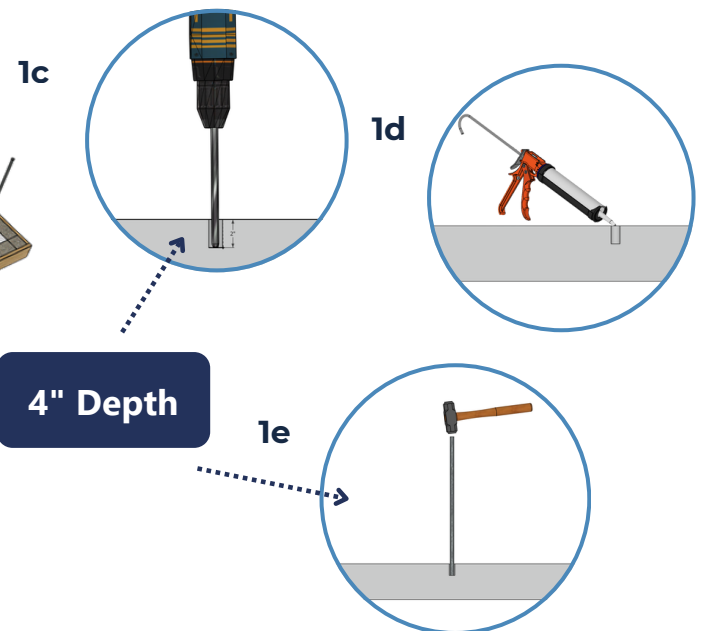
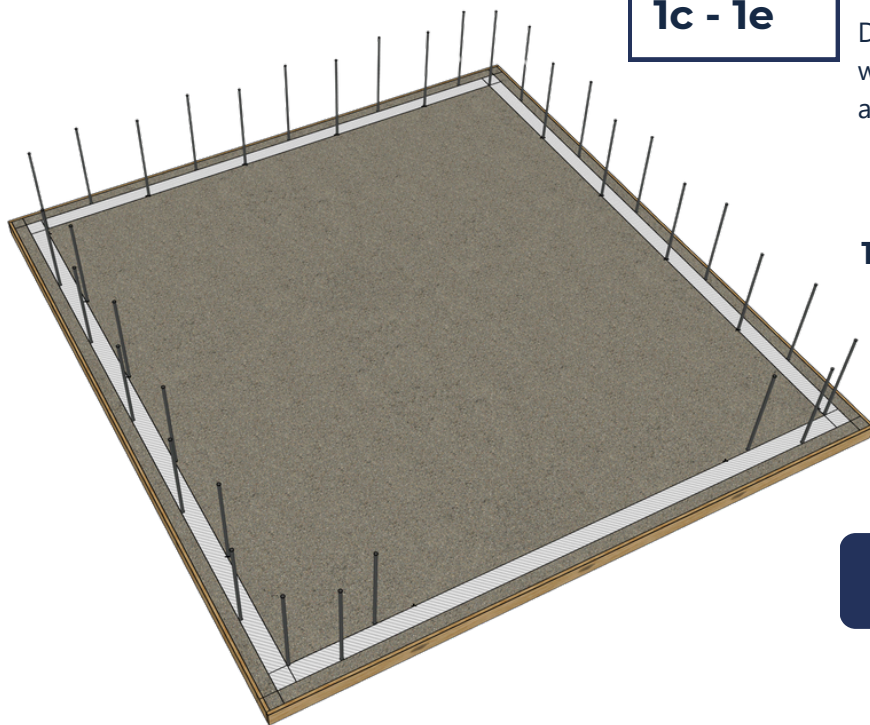

A **minimum slab dimension of 14' x 14'** is recommended to provide adequate working space for panel installation, bracing, and material handling during construction. Larger slab dimensions may be required depending on the building layout and site conditions.



2 Panel Placement with Rebars and Anchoring

Position wall panel assemblies vertically along marked wall lines, sliding them over pre-installed rebars, then secure using c-clamps or tie wire for structural stability.

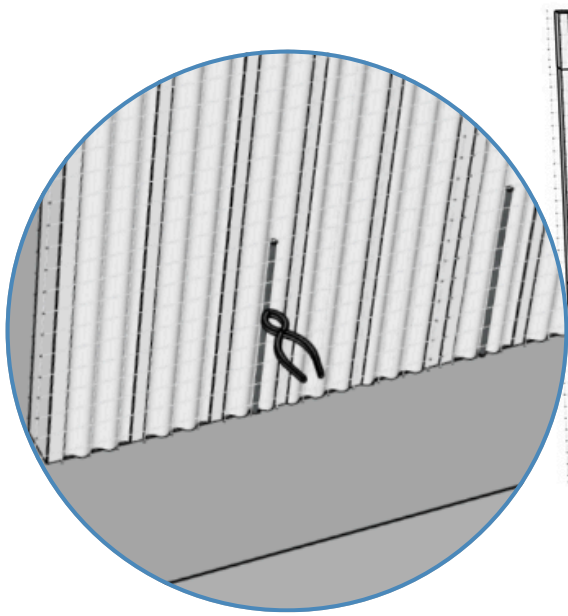

Wall Panel Assembly:
See Page 5

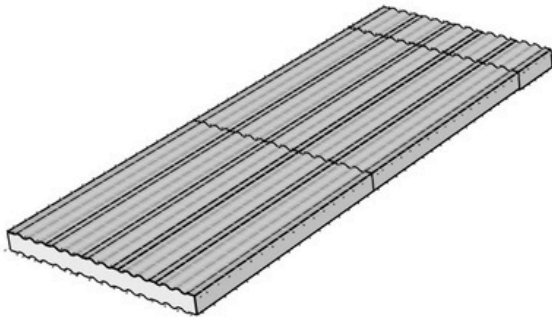
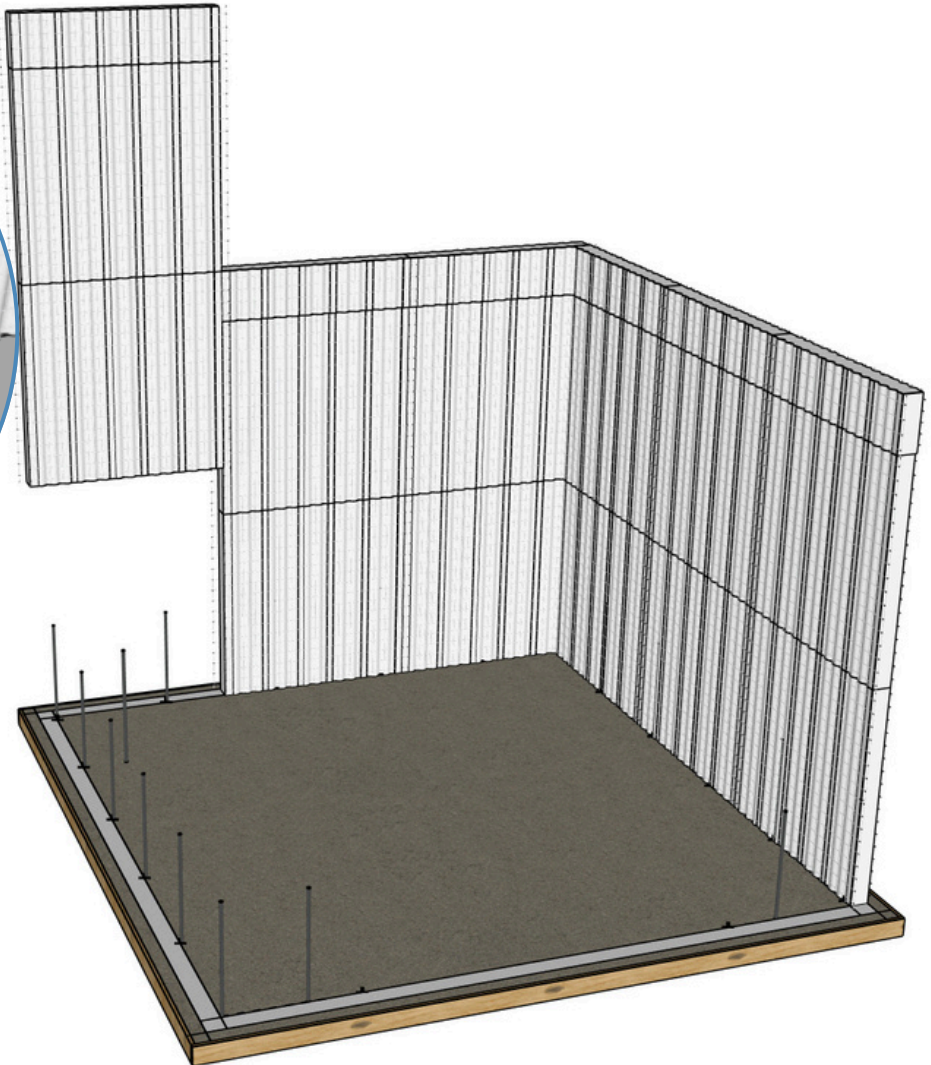

2a

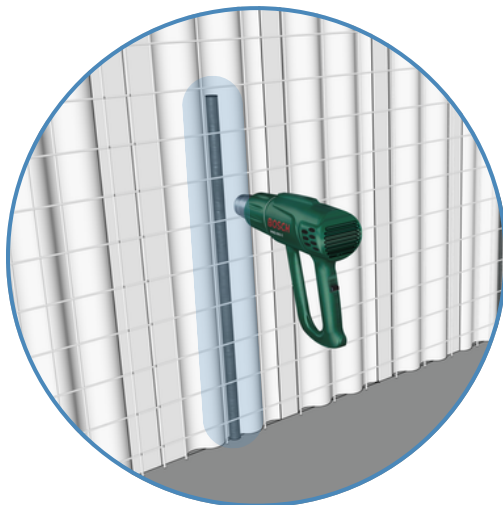

2a

Prepare Panel Base and Slide Over Dowels

Use a heat tool to melt a groove at the panel base, then lower the panel over rebars, guiding them between the foam core and exterior mesh.



2 Panel Placement with Rebars and Anchoring

Position wall panel assemblies vertically along marked wall lines, sliding them over pre-installed rebars, then secure using c- clamps or tie wire for structural stability.

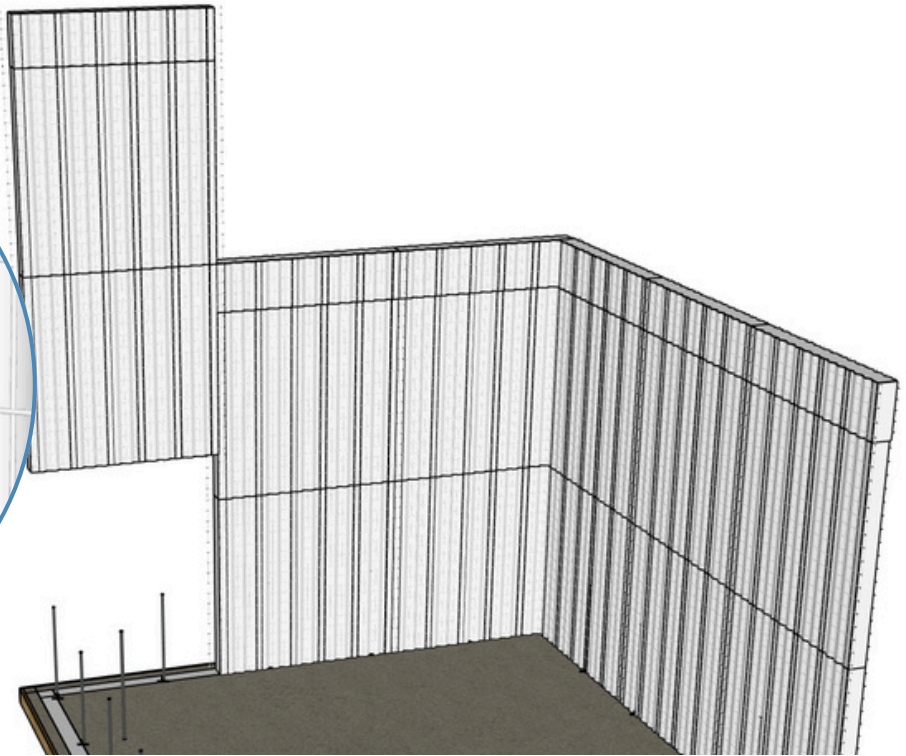

Use At Least 12 C-Staples/ties per Vertical Joined Section

2b - 2c

Overlap and Tie Mesh Between Panels

Align panels so edge meshes overlap on both sides, then add c-rings on the seams securely every 2 feet using a Pneumatic C Ring Gun.

2b

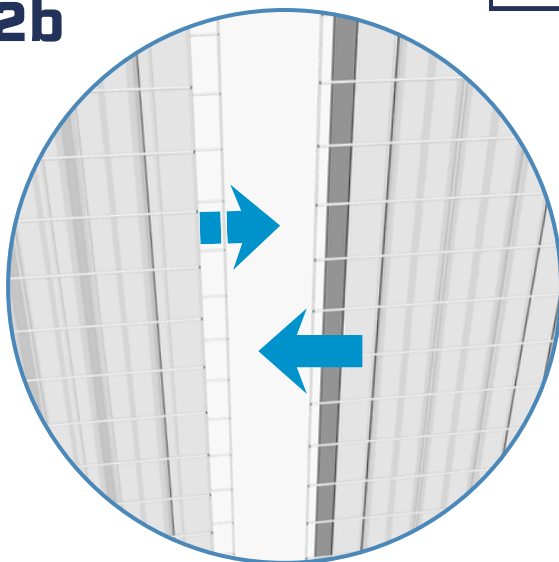

2c

2'

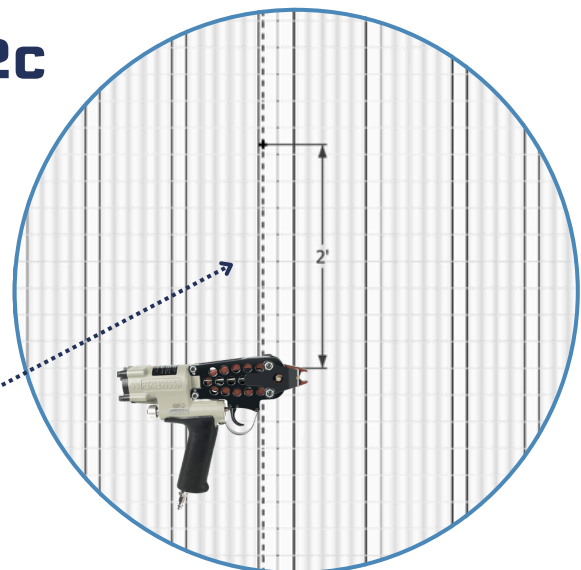

3

Cutting Your FortiUnit Door Opening

IMPORTANT: Before erecting the wall designated for the FortiUnit doorway, connect **three (3) wall panel assemblies** and lay them flat to mark the doorway opening cut lines. Clip the wire mesh along the marked lines on both the interior and exterior faces, then cut the foam core along the same lines before erecting the wall assembly onto the slab.

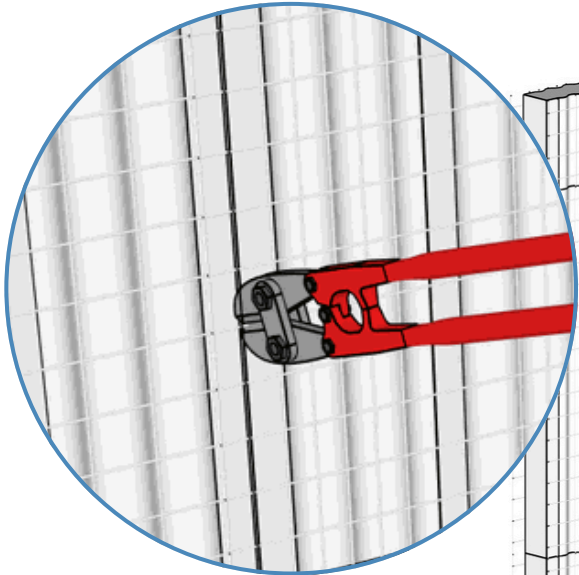

Cut the wire mesh along the marked cut line using pliers or appropriate wire cutters. Next, use a heat knife to cut cleanly through the EPS core along the same line to complete the panel section.

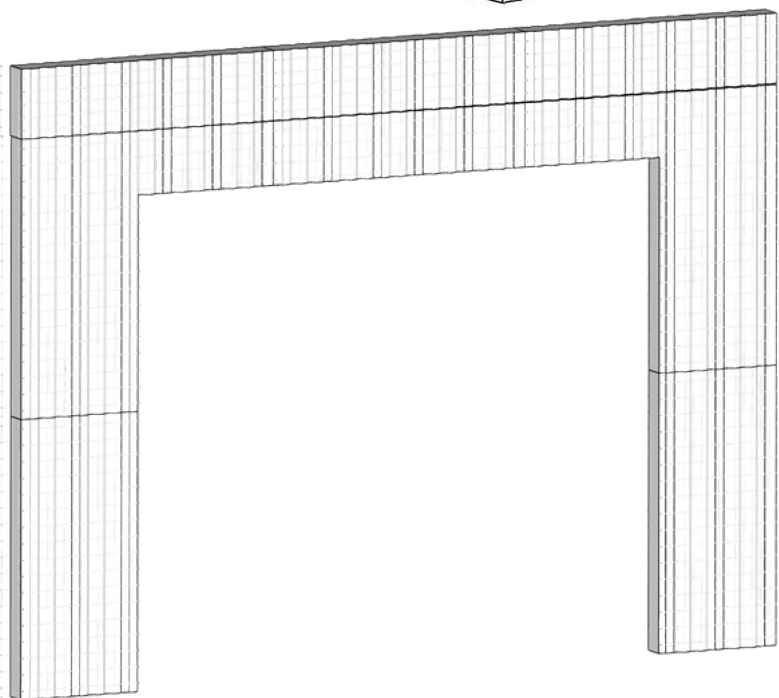
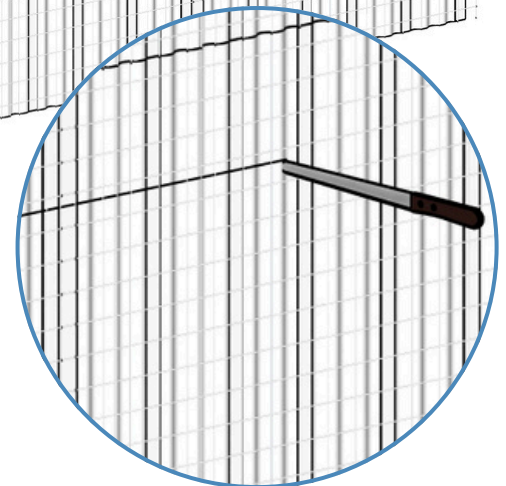
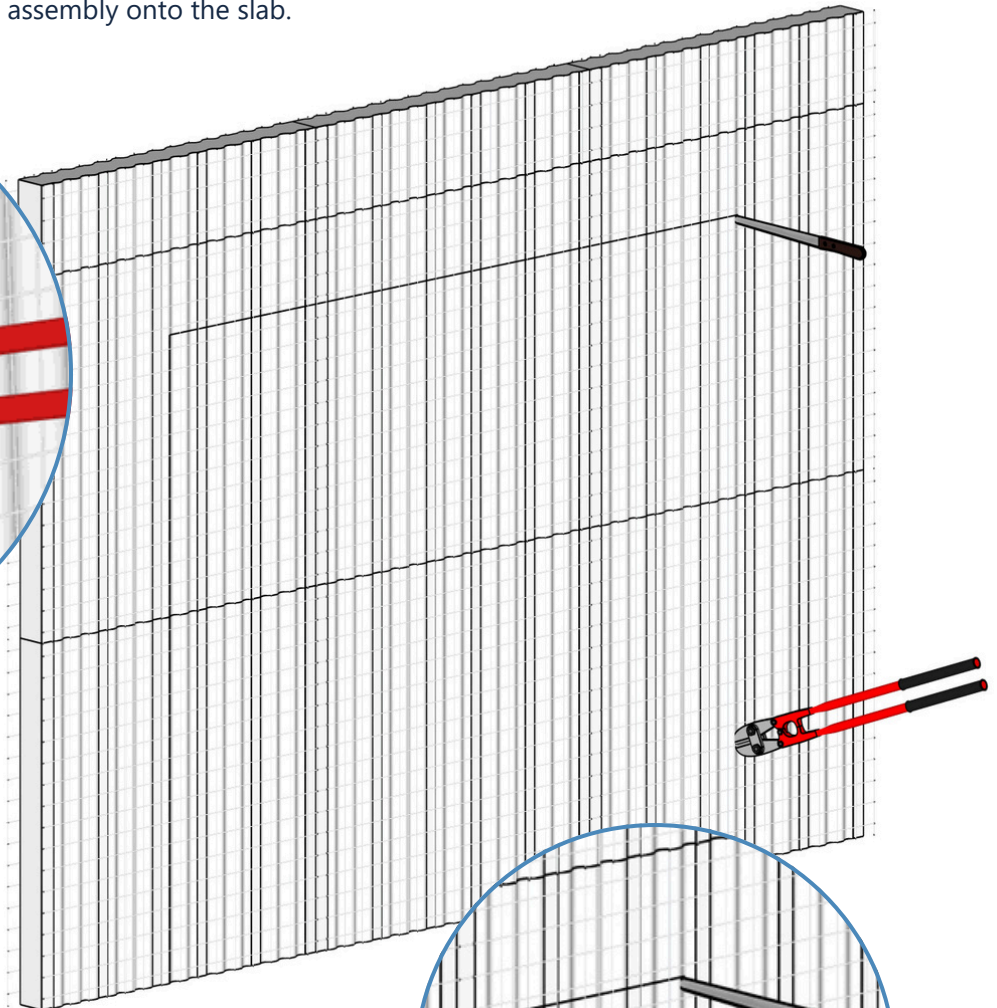

Door Opening Dimension Note:

When marking and cutting the FortiUnit doorway, verify the product specifications of the door being installed and size the foam cut opening accordingly. Allow for 2 inches of concrete on all sides of the foam cut line, as this concrete thickness will be added during shotcrete application and will define the final finished opening dimension for door installation.

4

Panel Alignment and Bracing

Use a level and plumb line to ensure each panel is vertically aligned. Secure panels with braces fixed at an angle and anchored to the slab or formwork to hold position during installation.

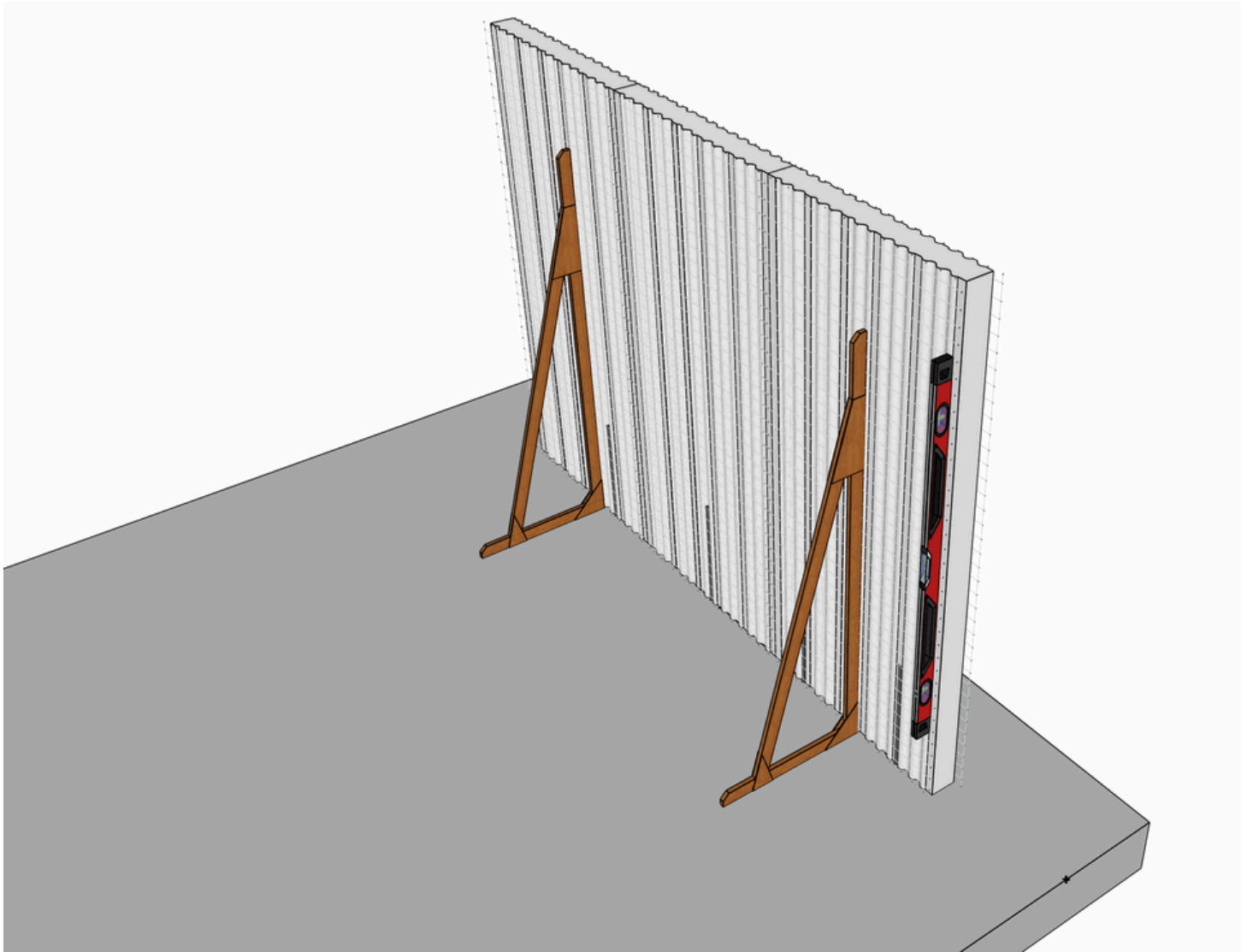

Bracing Options:

- Wood 2x4s: Easy to cut and nail into angled supports.
- Adjustable metal poles: Also called "jack posts" or "telescoping braces," these can be tightened by hand.
- Metal braces with clamps: Pre-made supports that can be locked in place with simple clamps.
- L-brackets with threaded rods: Useful for tight areas; rods can be turned to adjust pressure.

5

Installing Corner Mesh for 90° Panel Connections

Attach L-shaped mesh to the inside and outside corners where wall panels meet at 90°. Tie or c-clamp the mesh securely to the panel wire on both sides to reinforce the joint and lock the walls together.

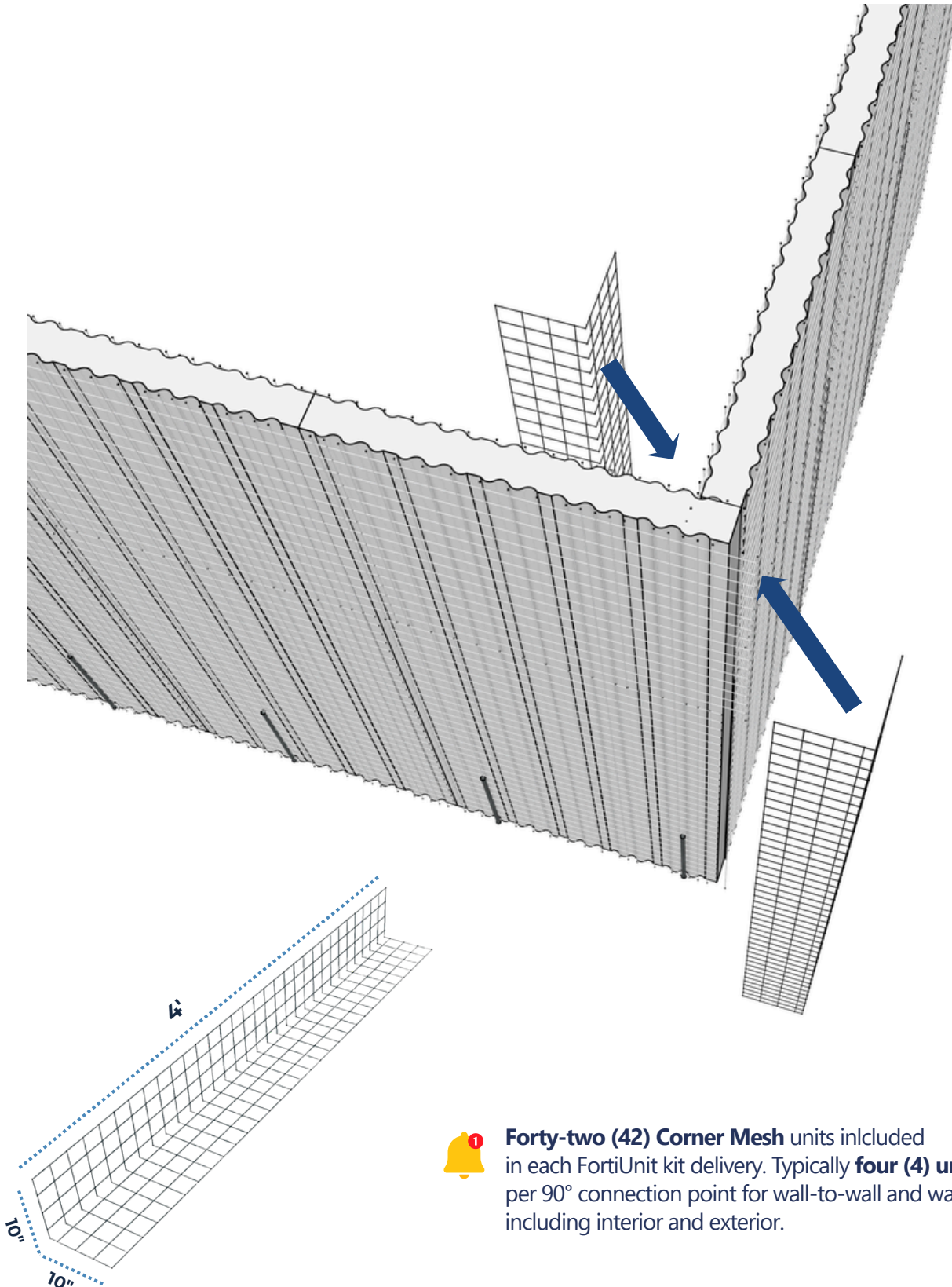

Forty-two (42) Corner Mesh units included in each FortiUnit kit delivery. Typically **four (4) units** needed per 90° connection point for wall-to-wall and wall-to-roof, including interior and exterior.



6

Accessory Mesh Installation for Structural Reinforcement

Install additional mesh reinforcements at key stress points to strengthen the panel assembly before concrete application. This includes U-mesh along panel edges and around openings, and flat mesh placed diagonally at corners of windows and doors to prevent cracking.

6a

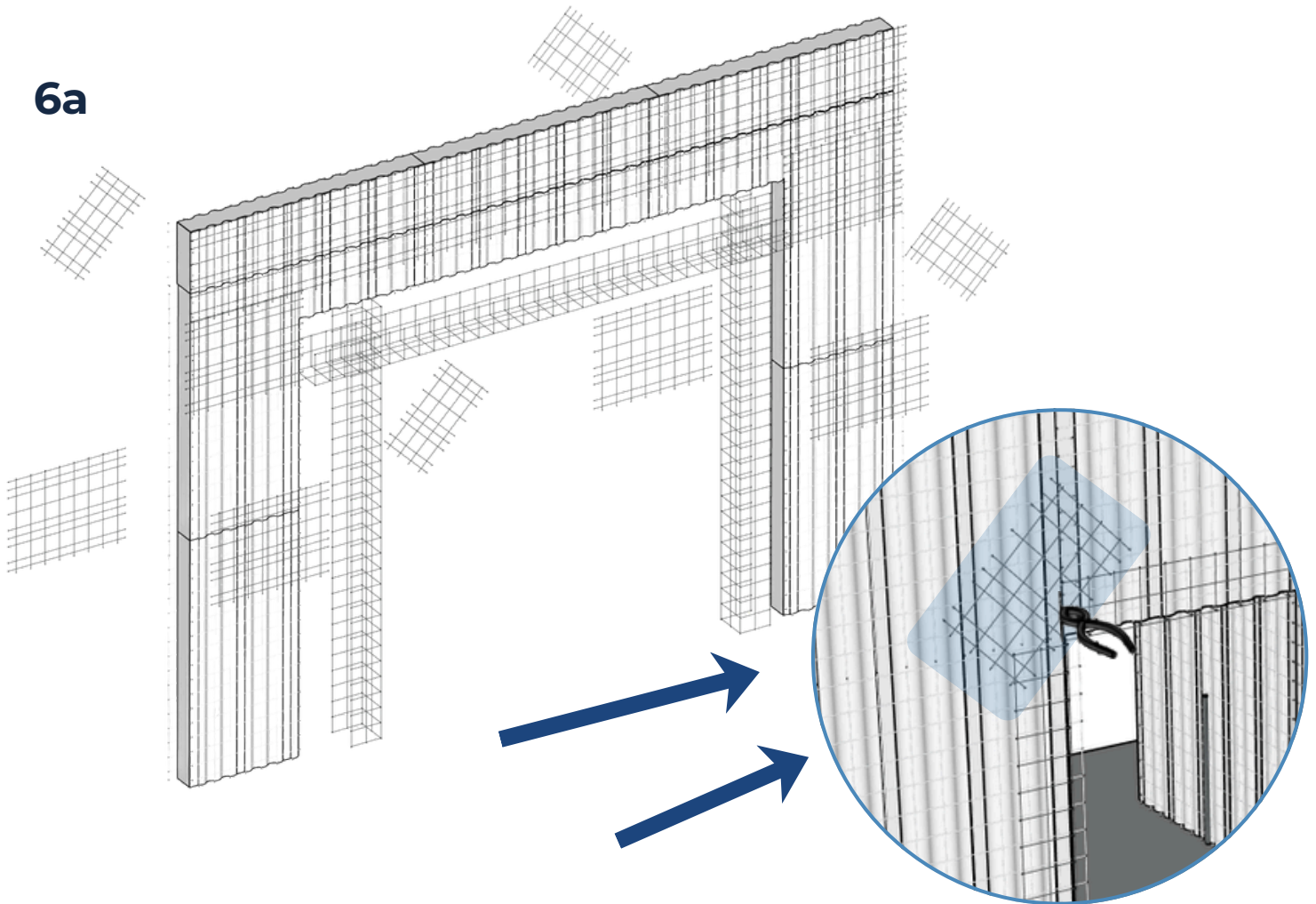

6b

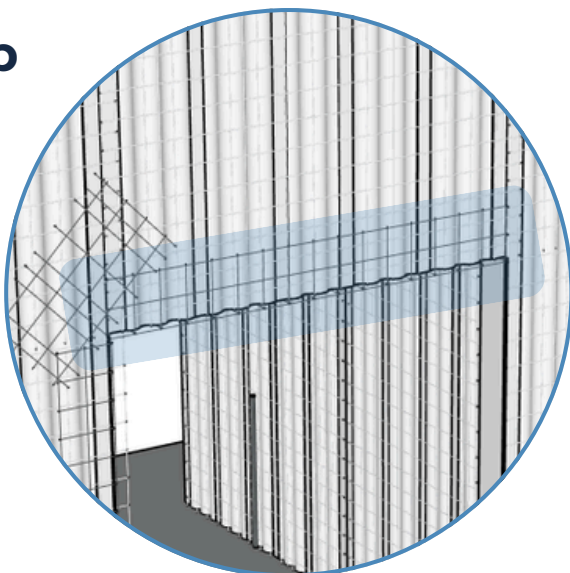

6a - 6b

Reinforcing Openings with U-Mesh and Flat Mesh

Wrap U-mesh around the full perimeter of your FortiUnit door opening, then place flat mesh diagonally at all corners to strengthen against cracking and movement.



7 Roof Panel Installation

Place roof panels onto the aligned wall perimeter in the correct orientation to achieve full coverage. Panels are sized at 47.25" wide—when assembled properly, they form a complete 12' span. Incorrect orientation will result in a 2-1/4" shortfall, creating gaps at the front and rear.

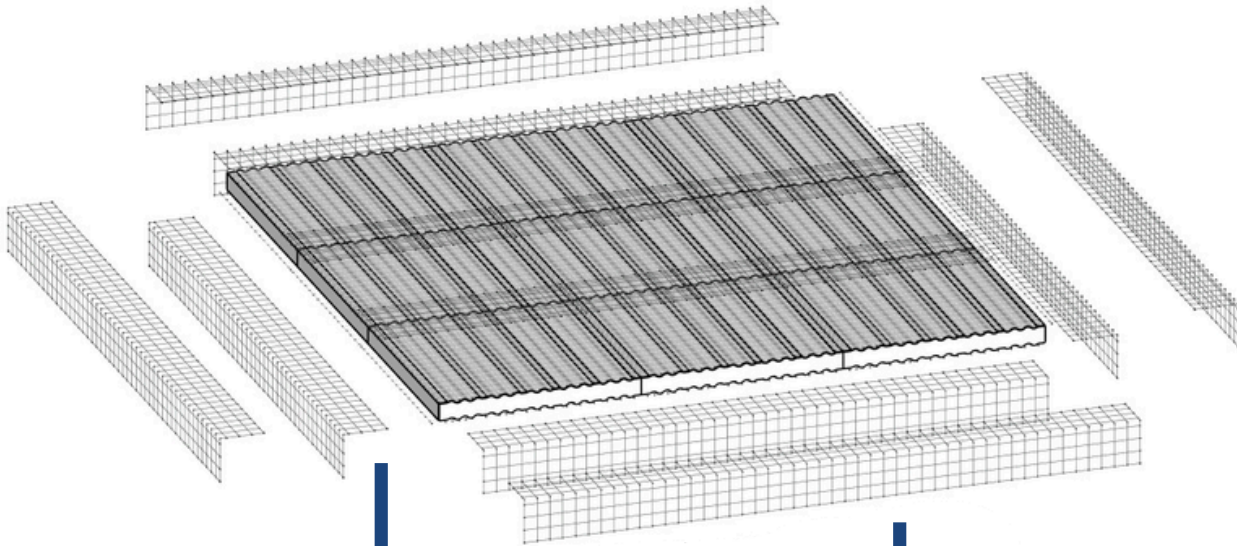

1 Verify panel layout direction before securing. Once positioned, ensure panels bear fully on supported edges, tie overlapping mesh seams, reinforce with corner mesh, and install temporary shoring below until concrete is placed and cured.

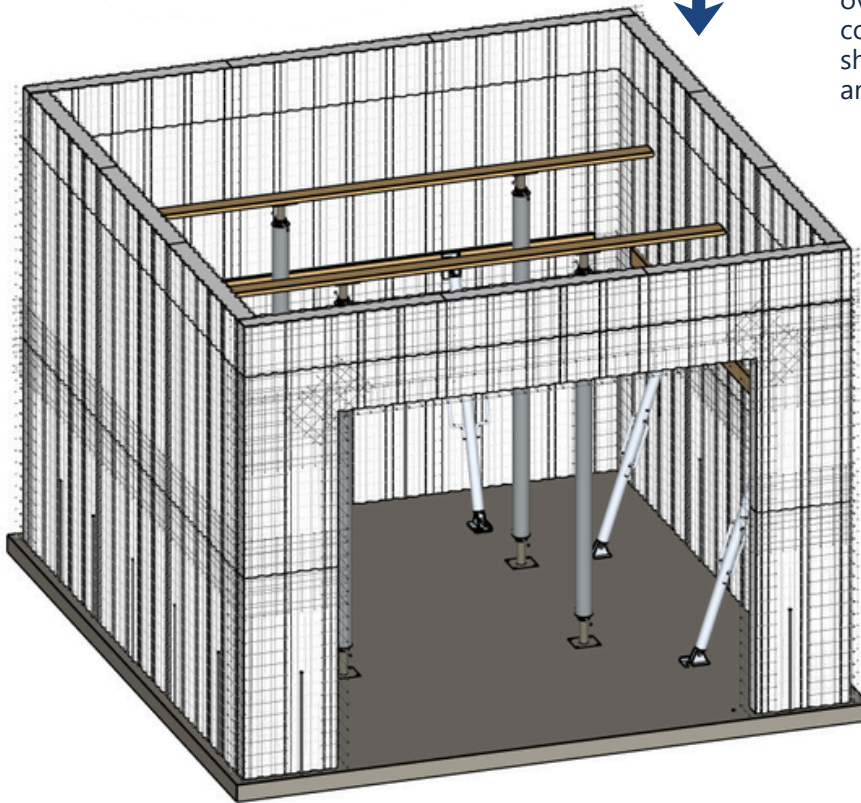

8

Completed Structure Assembly before Concrete

The fully assembled panel structure should be square, plumb, and fully braced, with all mesh connections tied or c-clamped and reinforcement installed at corners, edges, and openings. Verify that all panels are securely anchored, shored, and ready for concrete application.

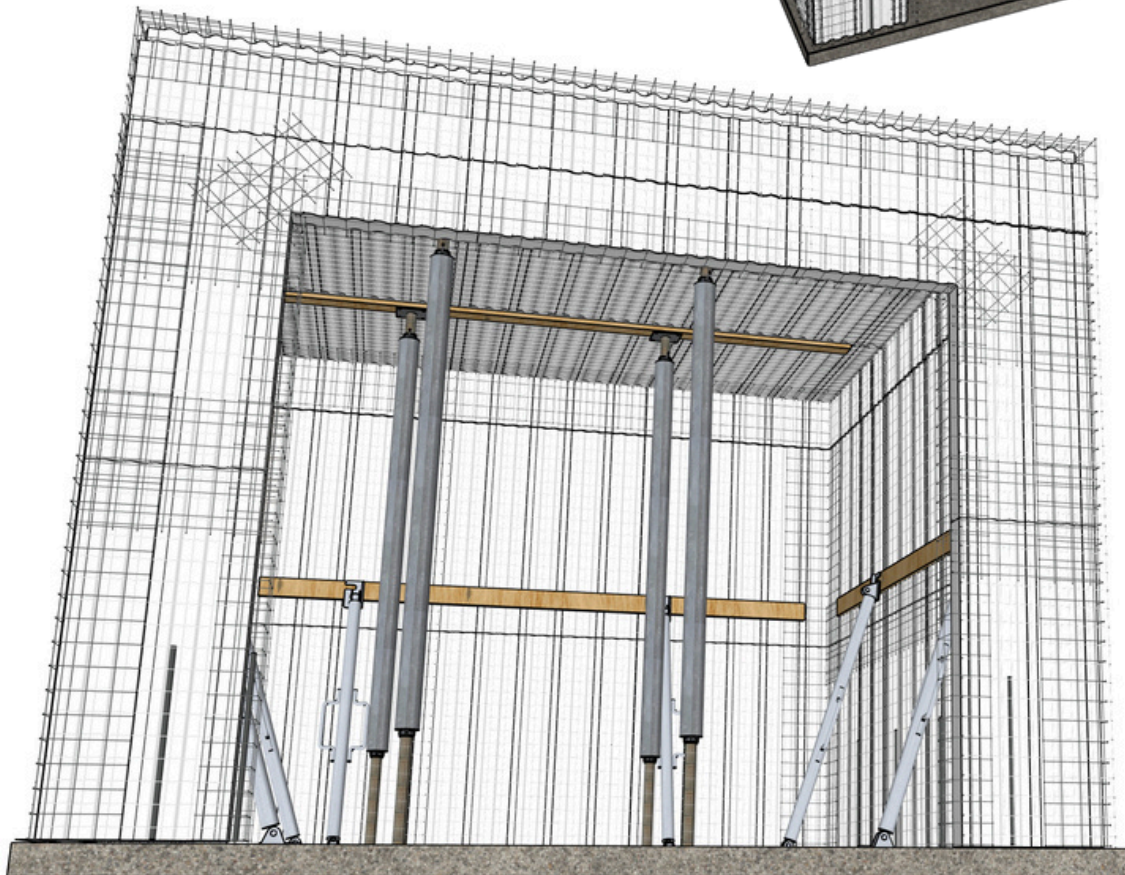
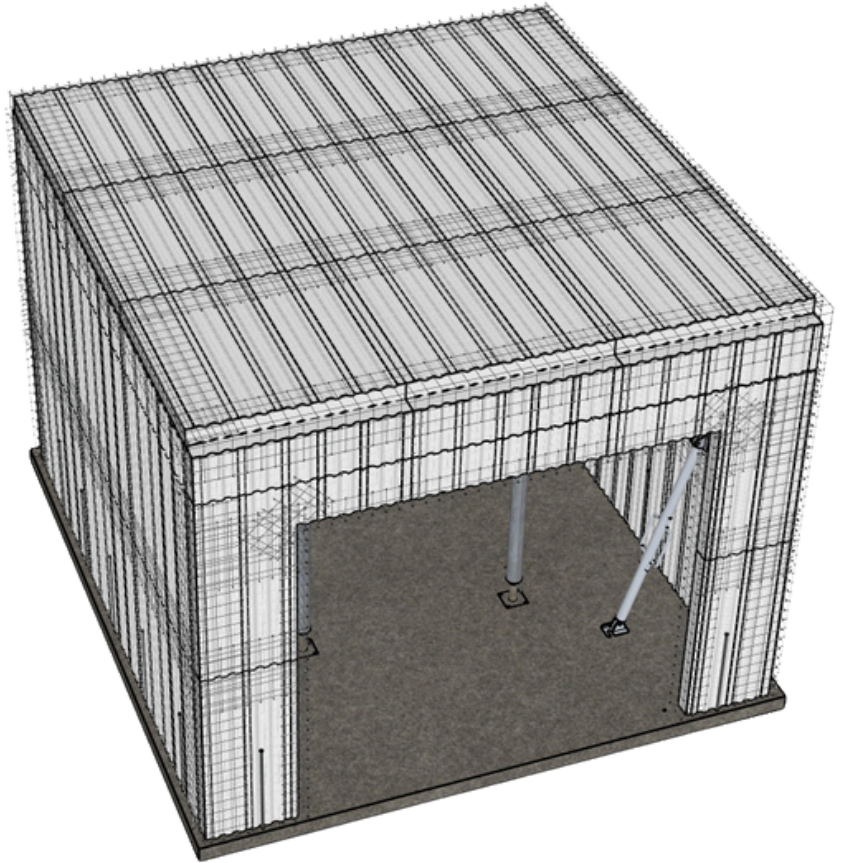

WET MIX MORTAR RECIPE

Find links to recommended materials at store.fortifiedstructuralsolutions.com/tools

INGREDIENT	PER BATCH (3.5 CU FT)	TOTAL for 315 SQ FT (12 BATCHES)
Portland Cement (Type I/II)	85 lb = 1 full bag + ~10 lb	3,442.5 lb (~40.5 bags)
Clean Sand (ASTM C33)	~275 lb = 3.5 full 5-gal buckets	11,137.5 lb = ~142.8 buckets = ~4.13 cubic yards
Water	~34 lb = 4.1 gallons	1,377 lb (~165.1 gallons)
Synthetic Fibers (PP)	~0.25–0.3 lb = 1 heaping handful	12.15 lb total = 40.5 handfuls
Acrylic Bonding Agent	~0.4 gal = ~50 oz per batch	16.2 gallons total
Plasticizer (optional)	~5 oz = about 2/3 cup	202.5 oz (~6.3 quarts)

 **Notes:** The specified mix should achieve a compressive strength range of **approximately 3,000 to 4,500 psi**, depending on curing conditions and exact water content. This exceeds the minimum target of 2,500 psi and is suitable for structural wall coatings applied via sprayer.

The above table is based on estimated concrete coverage for one standard panel kit (315 sq ft at 1 3/8" thickness) and a mixing container with 3.5 cu ft usable capacity (4.2 cu ft total volume). Quantities are approximate and intended for field guidance only.

Disclaimer: Fortified Structural Solutions provides these mix proportions as general recommendations and assumes no responsibility or liability for faulty batching, mixing, or application. For best practices, users should consult ACI 506R (Guide to Shotcrete) and ACI 506.2 (Specification for Shotcrete). For permitted projects, always follow local building codes and project-specific engineering requirements.

Concrete/Mortar (applied in-situ)

- Compressive Strength > 2,500 PSI
- Thickness > 1" from Mesh
- Aggregate size < 5/8"
- Slump > 2"

**SCAN TO SHOP
RECOMMENDED
TOOLS &
MATERIALS:**







9

Add Forming Around Openings & Insert Piano Wire

Prepare and secure forming around all openings to ensure proper shape, alignment, and concrete containment. Insert piano wire vertically at regular intervals while the scratch coat is still damp, using it as a guide to control the brown coat thickness



 Maintain a minimum of 1" from the mesh. Secure the wire in place with tie wire or c-clamps to keep it straight and properly tensioned during application.

 Install wood or structural forming members around the full perimeter of the opening. Ensure all pieces are plumb, square, and securely braced to resist movement during concrete placement. Proper forming at this stage defines the final opening dimensions and finish quality—double-check alignment before proceeding.



10 *Apply Scratch Coat*

Spray a thin, even base layer of mortar (scratch coat) over all panels, just enough to fully cover the mesh and create adhesion for the next coat.

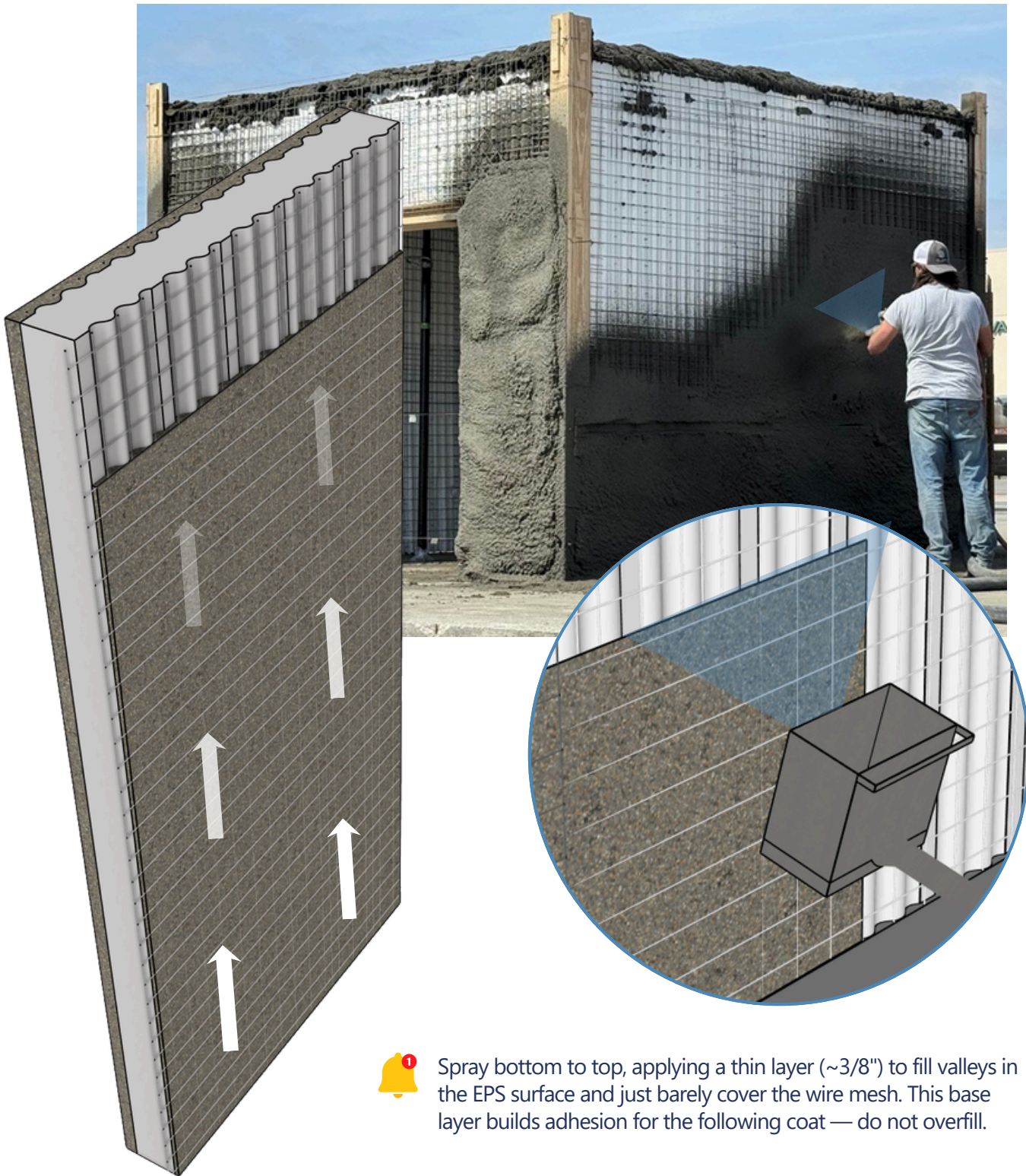

Spray bottom to top, applying a thin layer (~3/8") to fill valleys in the EPS surface and just barely cover the wire mesh. This base layer builds adhesion for the following coat — do not overfill.



11

Apply Brown Coat

Spray the second mortar layer (brown coat) to build up total thickness ($\geq 1"$), applying over and between the tensioned piano wires. Use the wires as a guide to maintain consistent depth across the surface.



The brown coat is the primary structural layer. Apply it over and between the tensioned piano wires to build up the full thickness, using the wires as a depth reference. This layer will be leveled in Step 14.

Per ACI guidelines, wait 4 to 24 hours after the scratch coat—until it is firm enough to support additional material without movement.

12

Screed the Wall Surface

Use a straight screed board or metal level to ride along the tensioned piano wires, striking off and leveling the brown coat surface.



For efficiency, consider spraying multiple 4 ft-wide sections before screeding, allowing you to level an entire wall or multiple walls in sequence—based on crew size and timing. Monitor weather and surface temperature closely; ideal conditions are cool and shaded to prevent premature drying.

Per ACI guidelines, begin screeding as soon as the brown coat holds its shape but remains workable—typically within 30 to 60 minutes after application, depending on conditions.

13

Corner Infill After Form Removal

Fill and consolidate all corner voids after removing forms to ensure a continuous, uniform surface.



After formwork is removed, inspect all corners for voids or gaps. Pack mortar firmly into these areas, fully encapsulating the mesh and tying into the surrounding brown coat. Strike flush with adjacent surfaces and finish to match. Proper consolidation at corners is critical for structural continuity and a clean final appearance.

14

Interior Wall Concrete Application

Apply the interior walls using the same steps previously outlined for the exterior walls—spray, smooth, and level as directed.

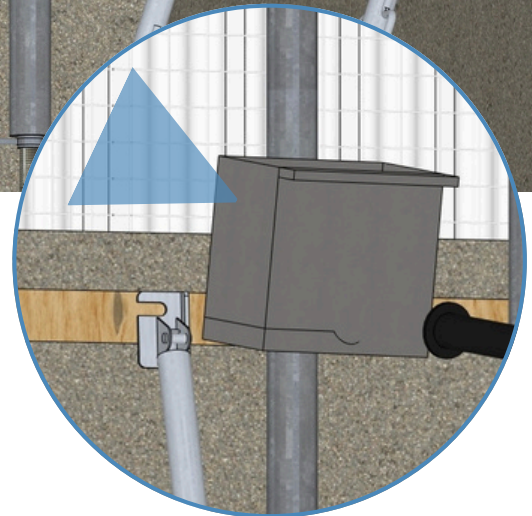
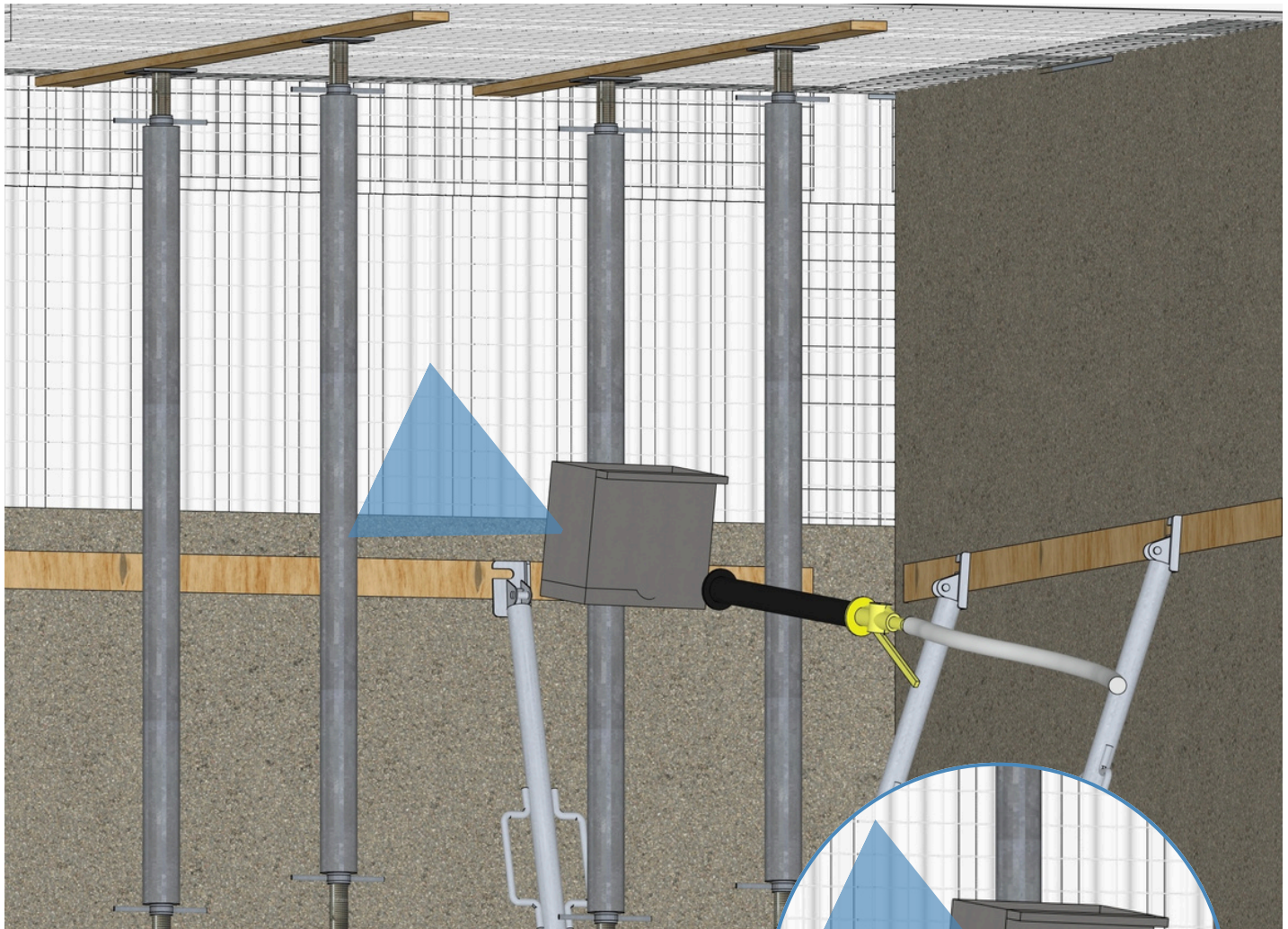

Finishing the interior walls before the roof pour allows them to cure and gain strength, so they can support the roof once the shoring is removed. Completing both exterior and interior walls first prevents cracking or separation under the weight of the fresh roof concrete.

15

Pouring Roof Concrete

Pour fresh concrete onto the top of the roof and spread it evenly, leveling the surface for a consistent, uniform finish.

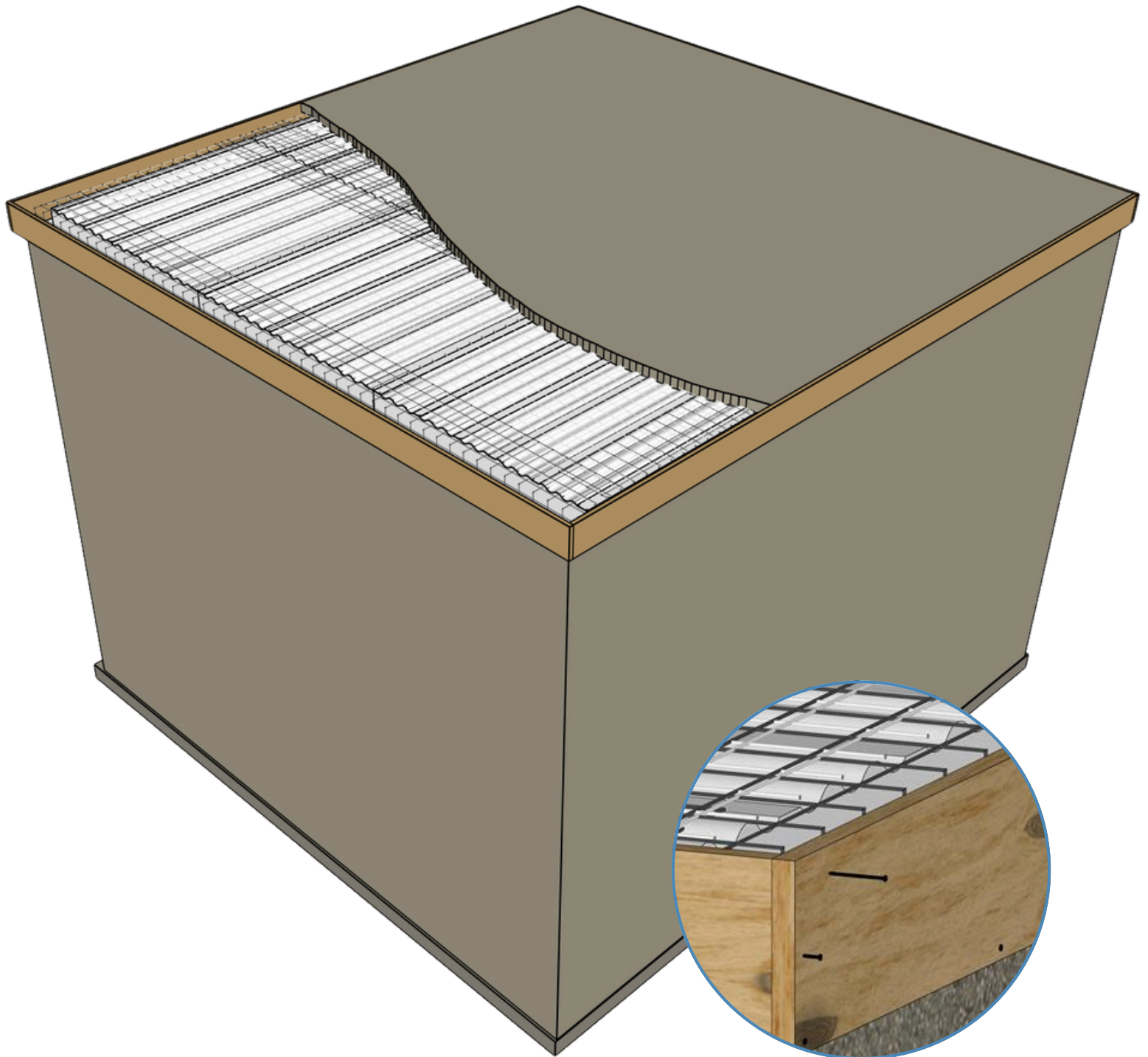

Secure wood forming around the top of the FortiUnit by nailing it directly into the concrete. Ensure forms are level and properly aligned to establish the correct thickness for the roof concrete pour.

16

Interior Roof Concrete Application

Apply the interior roof concrete by spraying it onto the underside of the roof only after the top roof concrete has cured.

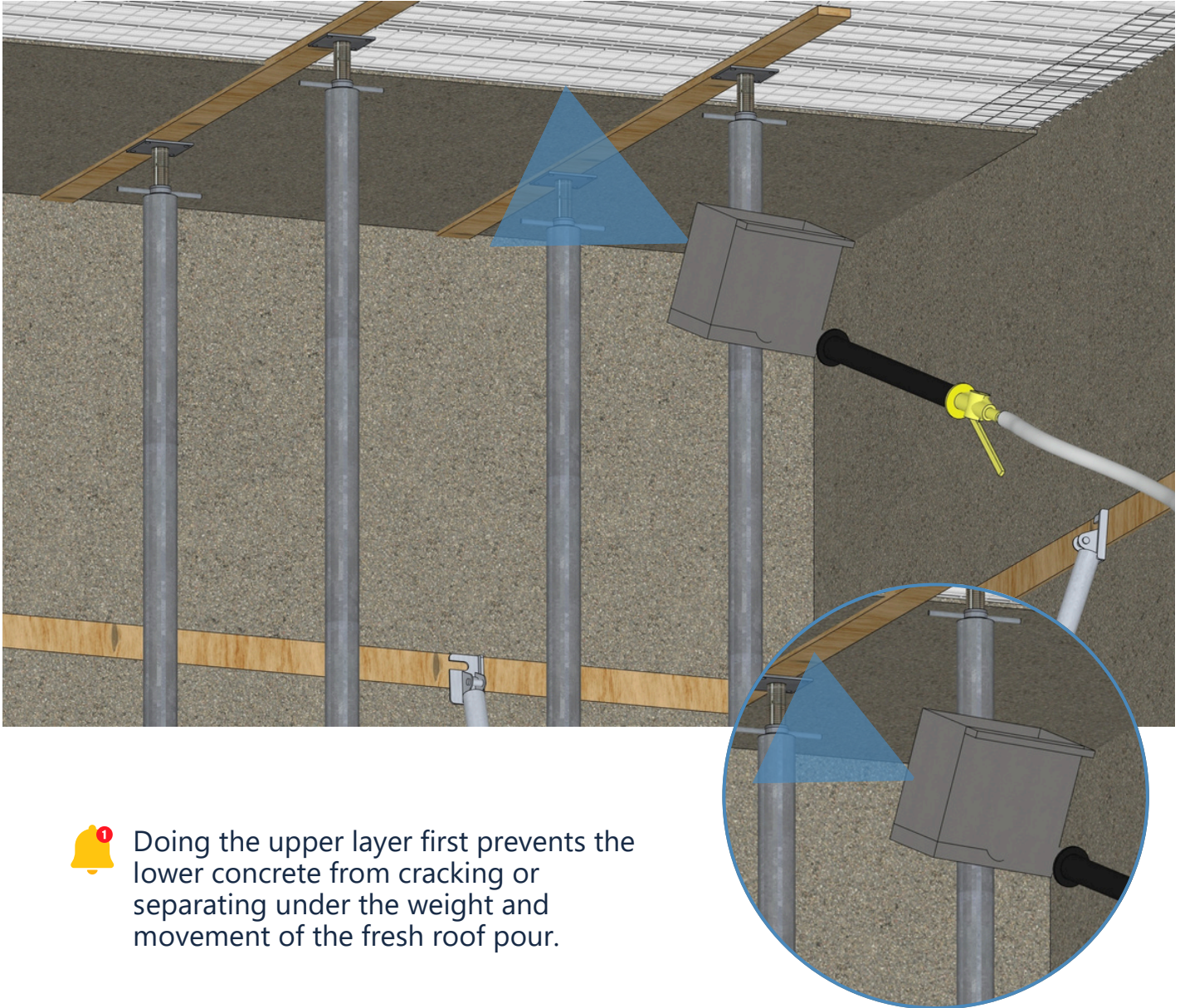

Doing the upper layer first prevents the lower concrete from cracking or separating under the weight and movement of the fresh roof pour.

17

Final Finish Layer

After the mortar cures, the wall only needs a waterproof sealant to protect it. Paint is optional for color and appearance. If desired, you can upgrade the finish later with a thin plaster coat, stucco, or other decorative surface treatment.



Bonus Tip: For added character, you can use roller stamps on the final coat to create realistic stone, brick, or siding patterns—an easy way to enhance the look without adding extra materials.

A clean, finished wall may require nothing more than waterproofing and, optionally, paint. More decorative finishes can be added at any time.



18

A Finished Unit Built to Perform

The completed FortiUnit is more than a finished structure—it's a ready-to-rent storage unit designed to generate value. With secure enclosed space, convenient roll-up door access, and a clean finished look, it offers owners an efficient way to create rentable storage and expand their income potential.



Whether used as a single unit or part of a larger layout, FortiUnit helps turn available space into a practical revenue-producing asset.

LEGAL DISCLAIMERS AND IMPORTANT NOTICES



Building Code Compliance

It is the purchaser's responsibility to ensure that the use and installation of this product comply with all applicable building codes and regulations, including but not limited to the Florida Building Code (FBC), International Building Code (IBC), or local municipal codes. The manufacturer does not guarantee code compliance in any specific jurisdiction. Verify with your local building department before beginning installation on a permitted or habitable project.

Installation Responsibility

This product must be installed in accordance with the manufacturer's installation instructions and all applicable building codes. While installation by a qualified, licensed professional is strongly recommended—especially for structural or permitted projects—experienced DIY users may perform installation at their own risk. Improper installation may result in structural failure, property damage, or personal injury, and will void any applicable warranty. All handling, installation, and jobsite safety are the sole responsibility of the purchaser or installer.

Limited Warranty and Liability

Unless stated otherwise in a written warranty document, this product is provided "as is" with no express or implied warranties, including merchantability or fitness for a particular purpose. The manufacturer's liability is strictly limited to replacement of defective product, if applicable, and excludes any incidental or consequential damages.

Disclaimer of Responsibility

FortiUnit is not responsible for:

- Misuse, unauthorized modifications, or off-label applications
- Engineering or architectural decisions
- Installation errors or field conditions
- Permitting or inspection issues

Refer to **ACI 506R** and **ACI 506.2** for best practices on shotcrete and structural panel system application.



BY ACCEPTING DELIVERY OF THIS KIT, THE CUSTOMER ACKNOWLEDGES AND AGREES TO THESE TERMS.

FortiUnit

